



model 7720DT



- 77 in. (1956 mm) probe cylinder stroke allows use of 60 in. (1,524 mm) probe rods
- Over 20 ton pulling capacity for today's larger sampling tools and deeper depths
- Equipped with the powerful GH62 Hammer
- Heavy Duty Undercarriage has a wider track that carries more weight, adds more torque, reduces ground pressure and handles greater tool weight
- Wireless remote control
- Built-in rotary spindle for concrete drilling, augering, and anchoring
- Equipped with a hydraulic winch for handling augers and tripping dual tube sampling tools
- Two-speed probe cylinder cycles from bottom to top in less than 8 seconds
- Powered by a four-cylinder, 54 Hp, liquid-cooled Kubota turbo diesel engine
- Hydraulic movement in all three axes allows easy probe alignment with tool string
- Auxiliary hydraulic ports provide power for remote equipment



Model 7720DT Specifications

Stroke.....	77 in.	1956 mm
Weight.....	7,100lb.	3221 kg
Width.....	60 in.	1524 mm
Length (folded).....	125 in.	3175 mm
Height (folded).....	89 in.	2260 mm
Height (unfolded).....	184 in.	4674 mm
Lateral Movement (side-to-side).....	33 in.	838 mm
Foot Travel.....	39 in.	991 mm
Extension.....	15 in.	381 mm
Down Force.....	35,000 lb.	160 kN
Retraction Force.....	47,000 lb.	214 kN
Hydraulic Pressure (system).....	2,450 psi	169 bar
Hydraulic Flow Rate (system).....	30 gpm	114 Lpm
Hammer System.....	GH62	
Percussion Rate.....	32 Hz	
Torque (hammer motor).....	560 ft. lb.	759 N-M
Rotation Rate (hammer motor).....	240 rpm (bi-directional)	
Fuel Capacity (diesel).....	15 gal	57 L
Engine (diesel).....	Kubota, 4-cylinder turbo	
Engine Power.....	54 hp	40 Kw
Outrigger Extension.....	16 in.	406 mm
Travel Speed.....	0-4.5 mph	0-7.2kph
Surface Load.....	3.7lb/in ²	0.26 kg/cm ²
Winch Rating.....	2,350 lb	1,067kg
Winch Speed.....	0-110 fpm	0-34 m/min

Augerhead Specifications

Torque (high torque/low speed).....	3,000 ft. lb.	4067 N-M
Torque (low torque/high speed).....	1,500 ft. lb.	2034 N-M
Hex adapter.....	1-5/8 in.	41 mm
Rotation speed (low speed/high torque).....	0-105 rpm	
Rotation speed (high speed/low torque).....	0-150 rpm	



Wireless Remote Control

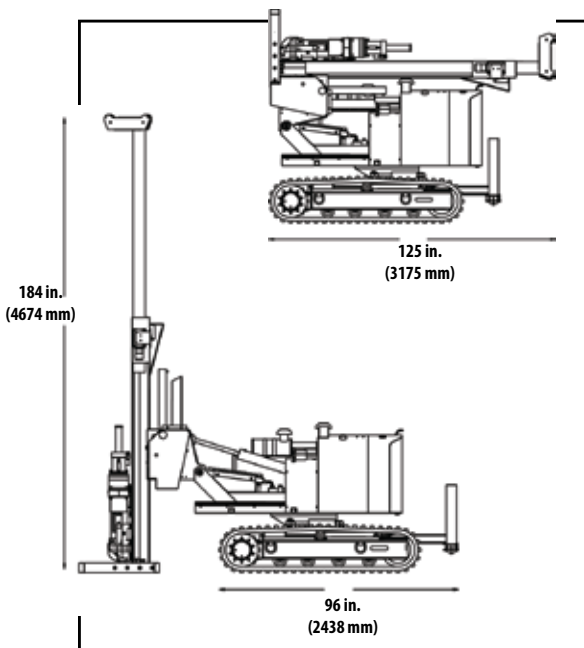

Geoprobe Systems

Model 6600/PC111 Model 8040DT Model 7730DT Model 6620DT Model 420M

E-specs

We have developed this E-specs document to allow you the ability to quickly compare the features and capabilities of various probe machines offered by Geoprobe Systems® ... the direct push innovators. Unit and tooling specifications are subject to change without notice. If you are interested in a specific Geoprobe® direct push system, please call us at **1-800-436-7762** for a formal, specialized quotation which includes all the details required for purchasing your Geoprobe® system.

Geoprobe Systems

1835 Wall Street • Salina, KS 67401
1-800-436-7762
www.geoprobe.com